



# VENTURA XP

ICE CREAM CABINET

## TECHNICAL HANDBOOK

# Index

## CONTENTS

1	TECHNICAL NOTES .....	3
1.1	Description of the cabinet .....	3
1.2	Work surface .....	3
1.3	Models dimensions and weights.....	4
1.4	Uncrating the cabinet .....	4
1.5	Technical characteristics .....	4
2	INSTALLATION .....	5
2.1	Transportation .....	5
2.2	Handling and Lifting off of the Pallet .....	5
2.3	Positioning the cabinet .....	5
2.4	Environmental Conditions.....	6
2.5	Service of condensing units and under frame components .....	6
3	FUNCTIONS .....	7
3.1	Start-up: .....	7
3.2	Command Console: .....	7
3.3	Keyboard .....	7
3.4	The meaning of the leds .....	8
3.5	How to visualise and change the set point .....	8
3.6	How to set up a manual defrosting cycle .....	8
3.7	The ON/OFF Function .....	8
3.8	Local Alarms .....	9
3.9	Automatic defrosting .....	9
3.10	Functioning with differentiated and reserve sector .....	9
3.11	Stopping the Machine: .....	10
4	ROUTINE MAINTENANCE.....	11
4.1	Preliminary .....	11
4.2	Condenser cleaning .....	11
4.3	Cleaning the interior storage compartment .....	11
4.4	External cleaning of the cabinet .....	12
4.5	Weekly Defrosting .....	12
5	PRACTICAL TROUBLESHOOTING GUIDE .....	13
6.	TECHNICAL DATA.....	15
7.	ELECTRICAL DIAGRAMS.....	16
8.	REFRIGERATOR PLANT DIAGRAM .....	24

Cod. 49041690010 Rev. 26-09-08

# 1 TECHNICAL NOTES

## 1.1 Description of the cabinet

The cabinet is essentially made up of four sections:

- 1) Glass Structure
- 2) Display Area
- 3) Frame
- 4) Cooling system

1) The glass structure is made up of two side panels of insulated tempered glass that have conductive heated strips to minimize condensation on the glass surface. The front glass is also insulated and includes heating strips to minimize fog and condensation. The top support frame includes the following components:

- Electronic control with temperature indicator
- Rear plastic doors and slides
- Product display light
- Service shelf

2) The display area is highly insulated with high density polyurethane so it has a low coefficient of conductivity. In the display area there are the evaporators and the ventilator fans which cool and dry the air and gently circulate it through the cabinet. In the interior is placed a bar which supports the rows of display pans. The pitch of the pans enhances the view of the display and allows for under storage of product depending on pan size used.

3) The frame structure is made of high quality, durable steel. In this structure all of the cabinets cooling, electrical and mechanical items are located for ease of service.

4) The cooling system is made up of:

- Condensing unit(s)
- Evaporator unit(s)

The condensing unit includes the compressor and the condenser. This assembly is mounted on tracks or rails which can be slid out to aid in the ease of servicing. The evaporators include the evaporator assembly with its own fan motors which keep the required temperature for the products placed in the display area of the cabinet.

## 1.2 Work surface

The work surface for the cabinet is located on the back part of the cabinet itself. Located here are the sliding rear doors and opening where the ice cream can be scooped from the cabinet.

NOTE: Directly below the rear work surface is the machine identification data plate. This data plate includes all of the machines pertinent information for servicing, model number, serial number and should be referenced when initiating a service call. See fig 1 below.



MANUFACTURED IN ITALY

---

MODEL NO. \_\_\_\_\_

SERIAL NO. \_\_\_\_\_

COMPRESSOR TYPE \_\_\_\_\_

VOLTS \_\_\_\_\_ PHASE \_\_\_\_\_ HZ \_\_\_\_\_

NO. OF REFRIGERATION SYSTEM \_\_\_\_\_

MAX.BREAKER/FUSE SIZE \_\_\_\_\_ AMP.

MINIMUM CIRCUIT AMPACITY \_\_\_\_\_

DESIGN PRES. HIGH SIDE PSIG \_\_\_\_\_

DESIGN PRES. LOW SIDE PSIG \_\_\_\_\_

REFRIGERANT \_\_\_\_\_ AMONT \_\_\_\_\_ OZ

	QTY	V	A	RLA	FLA
COMPRESSOR					
EVAPORATOR FAN					
CONDENSATOR FAN					
CONDENSATE PAN HEATER					
ANTI SWEAT HEATER					
LIGHT					
HEATED GLASS ASSEMBLY					

*fig. 1*

### ***1.3 Models dimensions and weights***

Please look at technical data

### ***1.4 Uncrating the cabinet***

#### **- Packaging**

Before removing any of the protective packing materials from around the machine, carefully inspect for any damage. This **MUST** be noted on the freight bill if damage has occurred and a freight claim filed.

### ***1.5 Technical characteristics***

Please look at technical data

## 2 INSTALLATION

### 2.1 Transportation

Two wooden rails are bolted to the bottom side of the machine frame structure of the cabinet. These wooden rails are in turn fastened to the main shipping skid or pallet, which holds the cabinet firmly in place during transportation. To remove the machine from the pallet, you must first remove these screws.

### 2.2 Handling and Lifting off of the Pallet

The display cabinet is lifted from the transport pallet in the following manner.

- Put the forks beside the machine as shown below.
- Ensuring that the forks are completely under the entire display cabinet and centered from side to side on the cabinet (see fig.2 below). You are now ready to lift off of the pallet.
- After removing from the pallet, place the display cabinet on the floor.
- To remove the wooden rails from the bottom, *CAREFULLY* lift and tip the display cabinet using the fork lift as illustrated in figure # 3.
- Unscrew the bolts which hold the rails to the bottom frame structure (fig.3 pos.A) and remove the rails from the supporting structure (fig.3 pos.B).
- Remove the other supporting structure and continue in the same way.

The movement and placement of the display cabinet must now be done by hand once it has been placed on the floor. *NEVER* push or try to move the cabinet by pushing or pulling on any side of the glass structure.

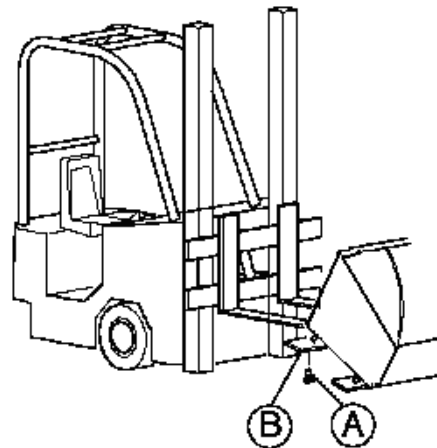
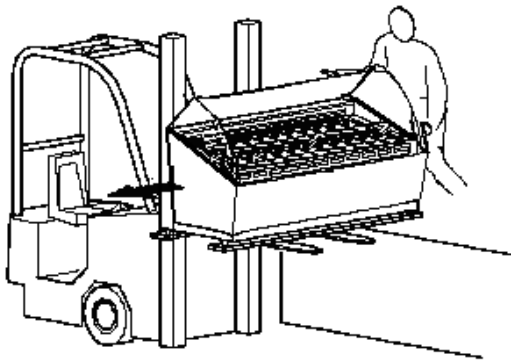

fig. 2

fig. 3

### 2.3 Positioning the cabinet

Before starting the installation, please ensure that the following clearances are maintained:

- A minimum space of 1500 mm (60 inches) customer side, and 700 mm (28 inches) operator side is maintained
- Check that there is an appropriate power supply is provided according to the local and or national standards.
- After the final position is located, seal base of the cabinet with silicone sealant to the floor along the bottom frame rail.
- Using a level, precisely level the cabinet front to back, side to side as shown.

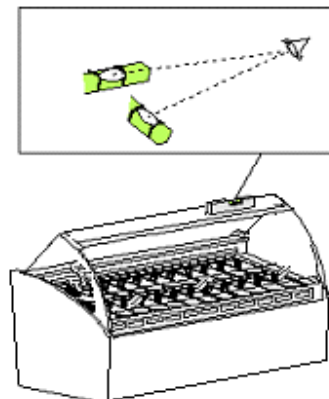

fig. 4

## 2.4 Environmental Conditions

When the cabinet has been positioned, please take note that its operation is affected by inside conditions. The temperature of < 30° C (85 F) and with a relative humidity of < 55% should be maintained to ensure proper cabinet operating conditions.

During the installation we must also check that:

- There is a sufficient air circulation and that there are no direct drafts onto the cabinet.
- The cabinet is not situated near any heat sources
- The cabinet is not exposed to direct sunlight at any time
- The grill for the air condenser is not obstructed, and air is allowed to flow freely
- Air conditioning or heating in the room are not directed near the cabinet.



IMPORTANT INFORMATION FOR USERS ACCORDING TO ART.13 LEGISLATIVE DECREE JULY 25, NO. 151 “ACCOMPLISHMENT OF DIRECTIVES 2002/98/CE, 2002/90/CE AND 2003/108/CE, CONCERNING THE REDUCTION OF THE USE OF DANGEROUS SUBSTANCES IN ELECTRIC AND ELECTRONIC EQUIPMENT, AS WELL AS THE WASTE DISPOSAL”.

The sign of the crossed bin on the equipment or on its packing indicates that the product must be gathered separate from other waste at the end of its life. The equipment waste disposal must be accomplished using the RAEE waste disposal centres specifically authorized. Users can contact their jobber/distributor/producer for information. The correct separate collection and subsequent recycling, treatment and the environment-friendly disposal of the equipment helps to prevent possible negative effects on the environment as well as health problems and promotes the re-employment and/or recycling of the equipment components. The product disposal without respecting the law implies the enforcement of administrative sanctions provided for by the rule in force.

It is essential to the proper operation of the case that all of the above items are strictly adhered to, all of which could adversely affect cabinet performance. It could also damage machine components, which will void the warranty on the machine and its components.

## 2.5 Service of condensing units and under frame components

In the event that service is required, it might be necessary to remove the condensing unit(s) from the cabinet. To do so, the rear panel must be first removed and adequate space provided to slide them out of the rear of the cabinet (see fig.5). It is therefore necessary to have adequate space behind the cabinet for this process to take place.

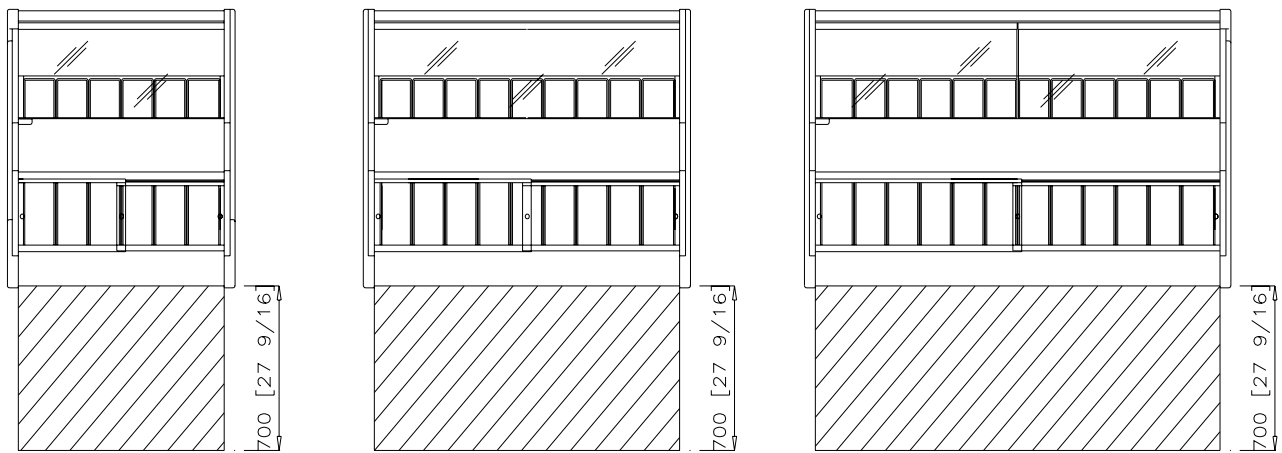
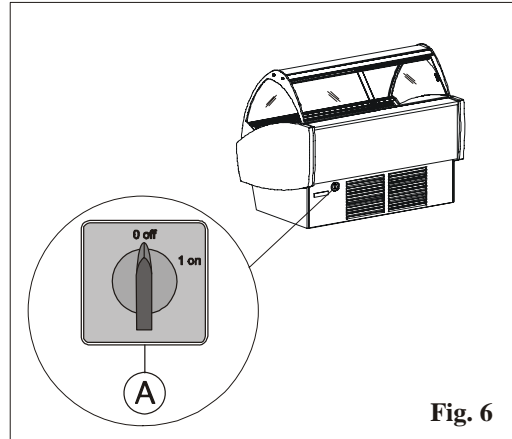

fig. 5

### 3 FUNCTIONS

#### 3.1 Start-up:

- 1) Activate the mains master switch.
- 2) Activate the display cabinet master switch, which is found on the rear protection panel. To introduce the electric power supply to the display cabinet, place the master switch at position “1” (fig. 6 pos. A).



#### 3.2 Command Console:







The refrigerating plant of the display cabinet is controlled by means of an electronic console. The electronic console consists of:

- 1) Keyboard
- 2) Control board

#### 3.3 Keyboard













T640: horizontal keyboard with 6 keys (185x38mm).

-  To visualise or change the set point. When programming this button is used to select a parameter or to confirm a value.
-  This button is used during programming for going through the parameter codes or for increasing their value.  
▲ If pressed and then released you will visualise the controlled section (LOC, SE2, ALL).  
▲ If pressed continually for 3 seconds this button allows you to gain access to the sections menu.
-  This button is used during programming for going through the parameter codes or decreasing their value.
-  Keep this button pressed for 3 seconds to start the manual defrosting cycle.
-  Use this button to turn the display cabinet lights on and off.
-  Turn the instrument on and off.



### 3.4 The meaning of the leds

There are a series of luminous points on the display, the meaning of which you will find in the table below:

LED	MODE	Function
	ON	Compressor on
	FLASHING	Programming phase (flashing with LED  )
	ON	Ventilator and evaporator active
	FLASHING	Programming phase (flashing with LED  )
	ON	Defrosting active
	FLASHING	Dripping time underway
	ON	Keyboard in "ALL" mode
	FLASHING	Keyboard in RVD mode (remote control)
	ON	ALARM SIGNAL - In the "Pr2" programme it indicates that the parameter is also present in "Pr1"

### 3.5 How to visualise and change the set point



1. Press the SET key and release it to see the set point: you will visualise the set point immediately.
2. To change the set point press the SET key and keep it pressed for 3 seconds: the led will flash  ;
3. To change the value activate  and .
4. To memorise the new set point, press the SET key or wait 15 seconds to exit the programming feature.

*N.B. It is very important to bear in mind that the optimal air temperature varies considerably with the variation of the composition of the ice-cream (in particular the percentages of sugars and fats). Before placing the ice-cream in the display cabinet you should wait about 45 minutes from the start-up of refrigeration in order to allow the plant to reach its set functioning temperature.*

### 3.6 How to set up a manual defrosting cycle



1. Press the DEF key and keep it pressed for more than 2 seconds.

### 3.7 The ON/OFF Function



By pressing the ON/OFF key the instrument will show "OFF".

In this configuration the loads of all of the regulations will be deactivated. To turn the instrument back ON press the ON/OFF key again.

The OFF condition allows for the exclusion of the instrument from monitoring without generating any type of alarm.

N.B. The LIGHT key remains active in the OFF position.



### 3.8 Local Alarms



MESSAGE	CAUSE	STATE OF OUTPUTS
“ P1 ”	Thermostat probe failure	Output according to “ Con “ and “ COF “ parameters
“ P2 “	Evaporator probe failure	Unchanged
“ P3 ”	Auxiliary probe failure	Unchanged
“ HA “	High temperature alarm	Unchanged
“ LA “	Low temperature alarm	Unchanged
“ EE ”	Memory anomaly	
“ EAL “	Digital input alarm	Unchanged
“ BAL ”	Blockage alarm from digital input	Regulation outputs deactivated
“ rtc “	Clock alarm	Unchanged
“ rtF “	Clock alarm failure / not present	Alarm output active, other outputs unchanged.

### 3.9 Automatic defrosting

The display cabinet is complete with an automatic “warm gas” defrosting system that allows for rapid elimination of ice formations on the evaporator fins. The automatic defrosting process is set in the standard configuration every 8 hours.

### 3.10 Functioning with differentiated and reserve sector

In this configuration the ice-cream display cabinet and the differentiated / reserve sector are controlled with a single keyboard. The luminous red coloured led that appears on the display on the left at the top indicates the section in which it is located, according to the following table:

	ON	Keyboard in “ALL” mode
	OFF	Keyboard in “LOC” mode (ICE-CREAM MACHINE)
	FLASHING	Keyboard in RVD mode (DIFFERENTIATED / RESERVE SECTOR)

Please follow the instructions below to change sections:

1. To change the section press this key for 3 seconds ▲ .



2. You will see the message corresponding to the current keyboard programming (LOC, SE2, ALL).
3. Select the selection that you wish (LOC, SE2, ALL) using the ▲ and ▼ keys.
4. Press the SET key to confirm and wait 15 seconds before exiting the programming mode.

The messages that appear on the display are as follows:

**LOC:** The keyboard shows the temperature values measured, the state of the outputs and the alarms of the section to which it is connected (Default: ice-cream machine section). All of the commands given by the keyboard will be carried out by the local section only (Default: ice-cream machine section).

To see the set point of the ice-cream machine section and change it you must therefore enter the local section (LOC) following the instructions outlined above and then follow the instructions given in paragraph 3.5;

**SE2:** The keyboard controls the section corresponding to number “2”(Default: SE2= differentiated / reserve sector) and shows the temperature values measured, the state of the outputs and the alarms of that section. All of the commands given by the keyboard will be carried out by that section only.

To see the set point of the differentiated / reserve sector and change it you must therefore enter the “SE2” section following the indications outlined above and then follow the instructions given in paragraph 3.5;

**ALL:** The keyboard shows the temperature values measured, the states of the outputs and the alarms of the section to which it is connected (ice-cream display cabinet), but the commands given by the keyboard will also be transferred to the other section (differentiated / reserve sector). “As2” will appear on the display in case of alarm, this indicates that the differentiated / reserve sector is in alarm mode. To see details of the type of alarm in question programme the keyboard in such a way that it assumes control of the differentiated / reserve sector.

*N.B. To turn on or turn off the ice-cream machine sector and the differentiated / reserve sector at the same time enter the “ALL” section and activate the ON/OFF function. To turn the ice-cream machine section on or off or the differentiated / reserve section on or off, enter the relative section ( LOC, SE2 ) and activate the ON/OFF function*

### **3.11 Stopping the Machine:**

To stop the plant act on switch (A), which is found behind the rear protection panel. Position the master switch at “0” (fig. 6 pos. A) disconnecting the display cabinet power supply.

## 4 ROUTINE MAINTENANCE

### 4.1 Preliminary

**WARNING! Before starting any maintenance or cleaning operation it is necessary to disconnect the power supply to the cabinet at the main power disconnect or breaker box.**

After turning off the power to the machine, you must then disconnect the main switch, which is located on the rear protection panel (see fig. 6).

### 4.2 Condenser cleaning

The dust and dirt deposits, generally situated on the fins of the air condenser, reduces the efficiency of the system and could eventually prevent it from functioning. It may also cause compressor damage if not cleaned regularly, so it is absolutely necessary to clean the condenser periodically (every 30 days). To do so, proceed as follows:

- Disconnect the power supply
- Removing the rear panel
- Remove the dust and the dirt in the condenser fins using a brush or a vacuum cleaner with a soft brush attachment (see fig. 7)

**WARNING! Do not use metal or rigid tools, as they could bend the cooling fins which could reduce efficiency or damage the condenser tubing.**

- Reinstall the rear panel
- Reconnect power to the machine

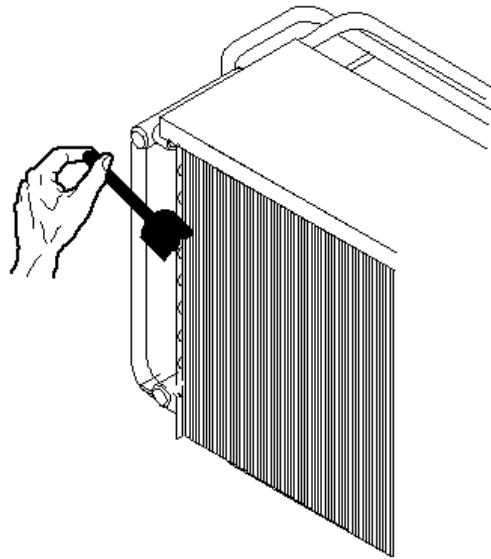

fig. 7

### 4.3 Cleaning the interior storage compartment

The interior of the cabinet needs to be cleaned periodically. Once a week is the recommended cleaning cycle for the inside display area. To clean, proceed as follows:

- Remove the product from the display cabinet and place it into a low temperature freezer
- Disconnect the power supply to the cabinet
- Allow the cabinet defrost for about 90 minutes
- Clean the interior of the cabinet with a sponge or cloth and warm water without detergents, as shown in fig. 8.

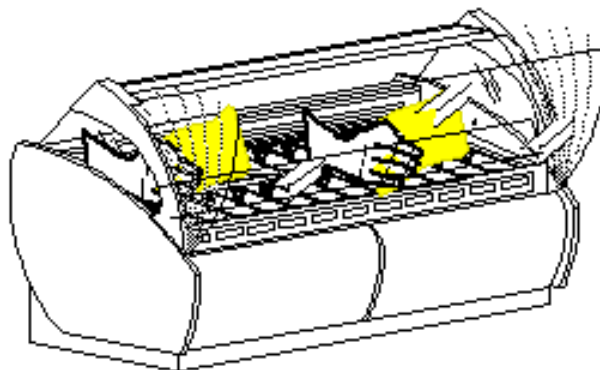

fig. 8

**WARNING! Avoid the use of large quantities of water as it could overflow the condensation collecting pan inside the cabinet frame**

#### **4.4 External cleaning of the cabinet**

The outside of the cabinet could be cleaned with warm water and mild detergent. When cleaning it is critical that you ***NEVER*** use steel wool, abrasives, glass paper or similar products. Never use aggressive chemical products such as acids, chlorines, ammonia, etc as it could damage or destroy the cabinet surfaces. Clean as indicated in fig. 9 with a soft cloth or sponge.

**WARNING! Absolutely avoid the use of pure alcohol.**

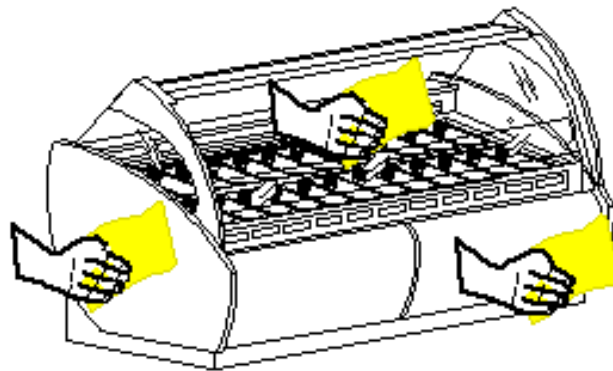

*fig. 9*

#### **4.5 Weekly Defrosting**

To ensure that the cabinet operates at maximum efficiency we suggest that you defrost the cabinet weekly and for a prolonged period (about 12 hours minimum). In order to do this, please disconnect the power supply to the cabinet. Allow the cabinet to stay idle for this prolonged period, which will ensure all ice has been defrosted and drained from the storage area.

## 5 PRACTICAL TROUBLESHOOTING GUIDE

### 1) The temperature of the display area is not low enough (the ice-cream is soft)

LIKELY CAUSE	LIKELY REMEDY
Evaporator obstructed by ice.	Carry out defrosting as indicated: Transfer the product from the display cabinet to a freezer at a temperature of $-20^{\circ}\text{C}$ . Turn off the main switch for 10 /12 hours so as to allow for the evaporator area to defrost (point 4.3).
Condenser obstructed by dust or other matter.	Clean the condenser as indicated in point 4.2 Remove everything that prevents a regular airflow to the condenser.
The ventilators are not working and / or their blades are damaged.	Request the intervention of the assistance service for the replacement of the same.
The display cabinet is exposed to air currents or direct sunlight	The display cabinet will not function correctly in these conditions; Remove the display cabinet from the air currents and / or direct sunlight
The thermostat is not working properly. With a perfectly functional refrigerating plant, the thermostat maintains a higher temperature in the air than that set.	Call the technical assistance service.
The refrigerated airflow (the “sheet of air”) on the ice-cream is irregular.	Check the air circuit (ventilator area, area beneath the evaporator) and remove any obstacles to the circulation of cold air.
Lack of water	Check if there is a water flow, if there is, call the technician for possible water valve rupture, pressurestat problems or other causes.

### 2) The defrosting water does not drain off properly (that is, the water obtained from the melting of ice during the automatic or manual defrosting phases).

LIKELY CAUSE	LIKELY REMEDY
The defrosting water drainage tube that goes from the cold tub to the tub in which such water is channelled (for evaporation) is blocked.	Open up the drainage tube
The display cabinet is positioned on the ground in such a way that the drainage water is not directed towards the outlet hole.	Ensure that the display cabinet is level on the ground as outlined in point 2.2. It must be completely level.

### 3) The compressor never stops or it works for very long periods of time.

LIKELY CAUSE	LIKELY REMEDY
The room temperature is very high (e.g. above +32°C).	If it is not possible to lower the room temperature (e.g. by means of air conditioning) the compressor will work almost constantly.
The air condenser is blocked	Clean the condenser as outlined in point 4.2
The thermostat is set too low.	Regulate the thermostat to a higher temperature as indicated in point 3.5
The ventilators are off.	Call the assistance service to individualise the cause and replace them if necessary.

### 4) The display cabinet does not work

LIKELY CAUSE	LIKELY REMEDY
The cabinet is not plugged in.	Plug it in (see point 2.6)
The trip switch has gone off.	Reinsert the trip switch.
The general switch of the display cabinet is off.	Turn on the general switch of the display cabinet (see point 3.1)

### 5) The light is not working

LIKELY CAUSE	LIKELY REMEDY
The light switch is not turned on.	Turn on the light switch
The fluorescent light bulb is not inserted properly.	Insert the light bulb properly.
The light bulb is blown.	Replace the light bulb
The “starter” is blown.	Replace the “starter”

## 6. TECHNICAL DATA

MODELS	COMPRESSOR'S ABSORBED POWER [W]	TOTAL ABSORBED POWER [W]	ELECTRICAL POWER SUPPLY	REFRIGERATING GAS	OPERATING TEMPERATURE FROM THE AIR [°C]	SIZE			WEIGHT [Kg]
						L-mm	D-mm	H-mm	
VENTURA XP G6	900	1410	380/3/50	R404a	-18/-20	1094	1141	1372	320
VENTURA XP G9	900 + 900	2510	380/3/50	R404a	-18/-20	1619	1141	1372	400
VENTURA XP G12	900 + 900	2770	380/3/50	R404a	-18/-20	2144	1141	1372	480

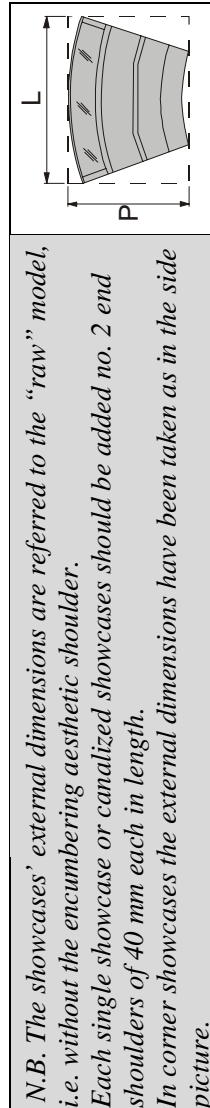

## 7. ELECTRICAL DIAGRAMS

The following electrical diagrams will have to be used by qualified personnel on the basis of the current regulations in vigour in the country of sale.

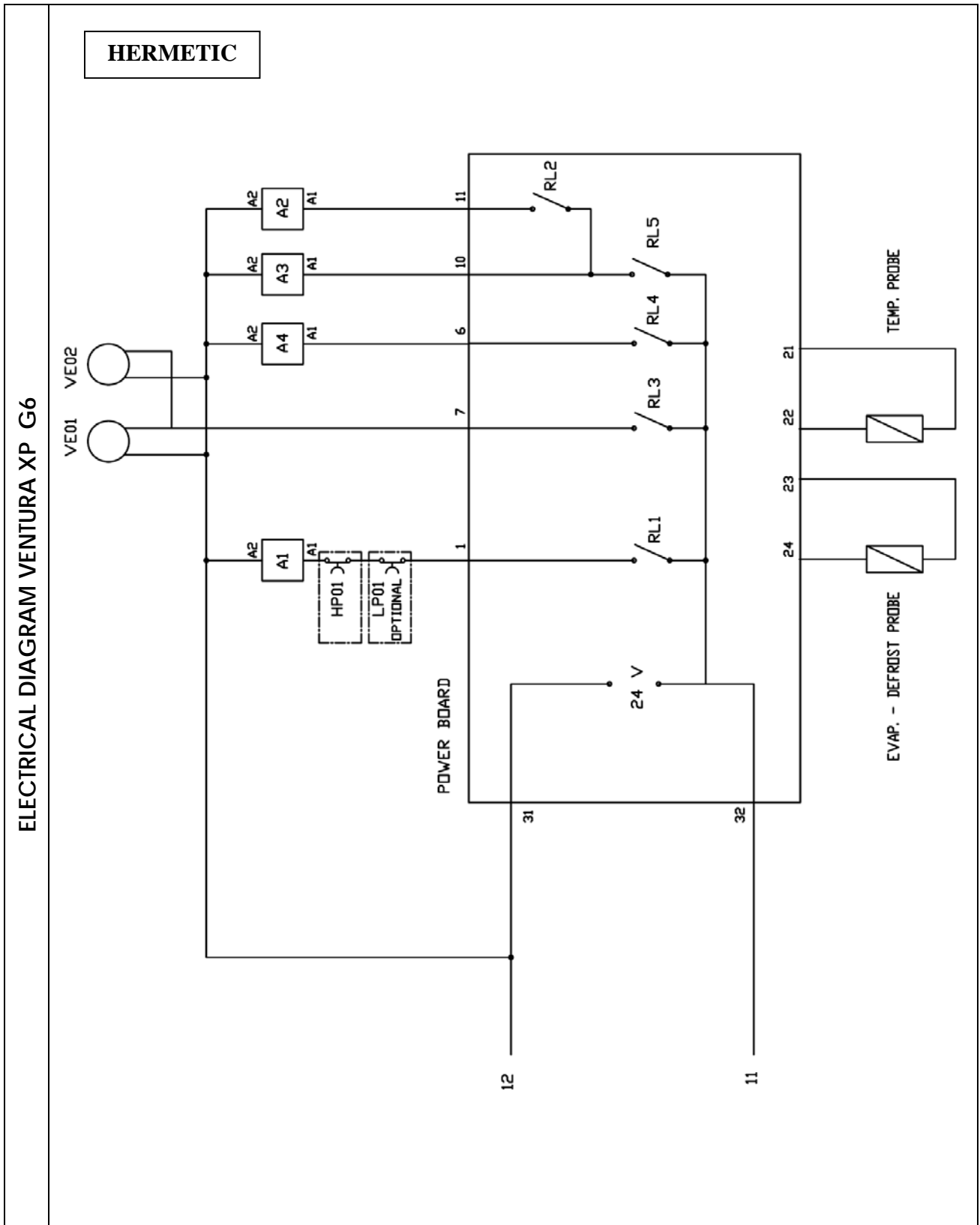



POWER WIRING VENTURA XP G6

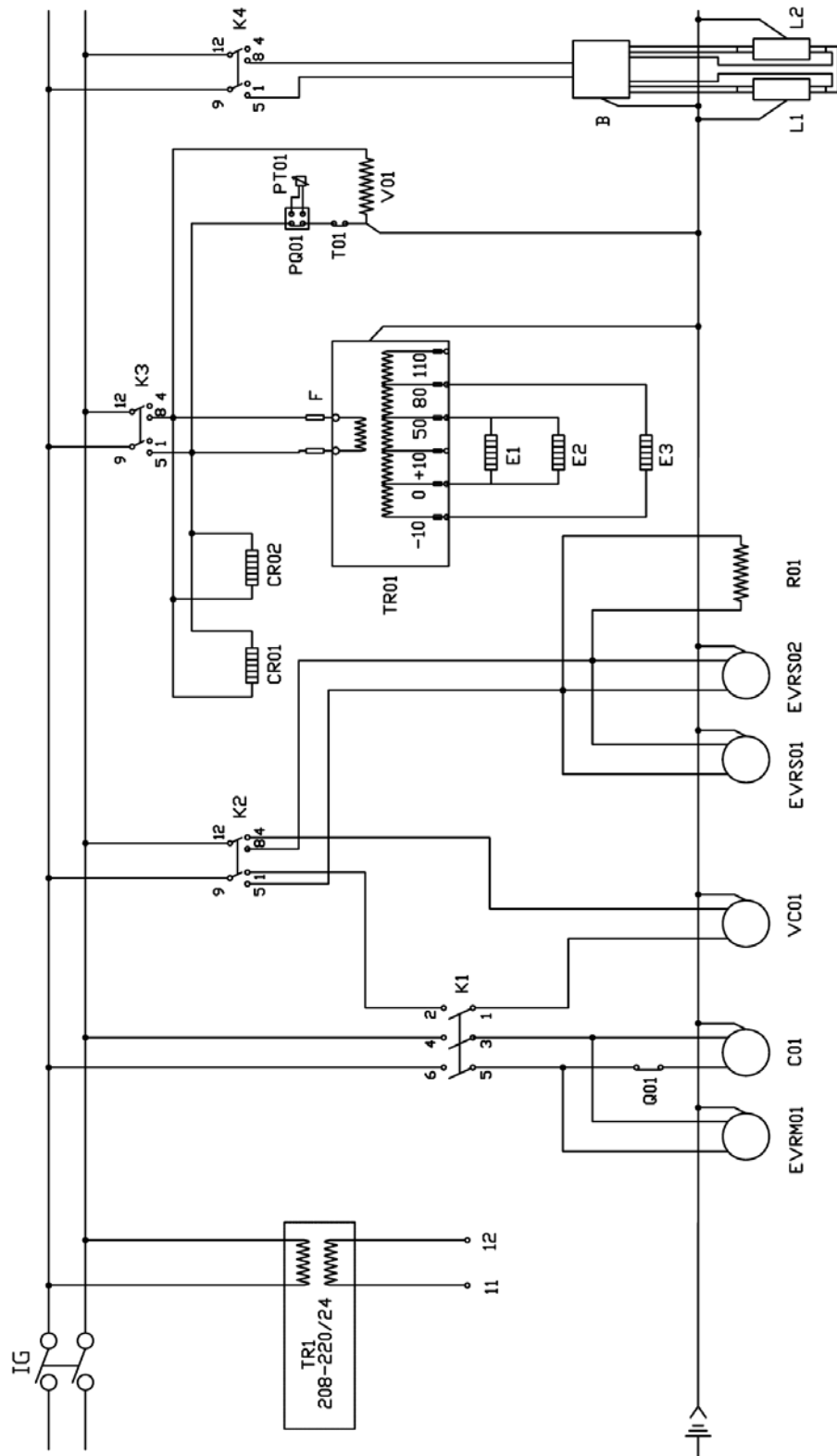



POWER WIRING VENTURA XP G9 - G12

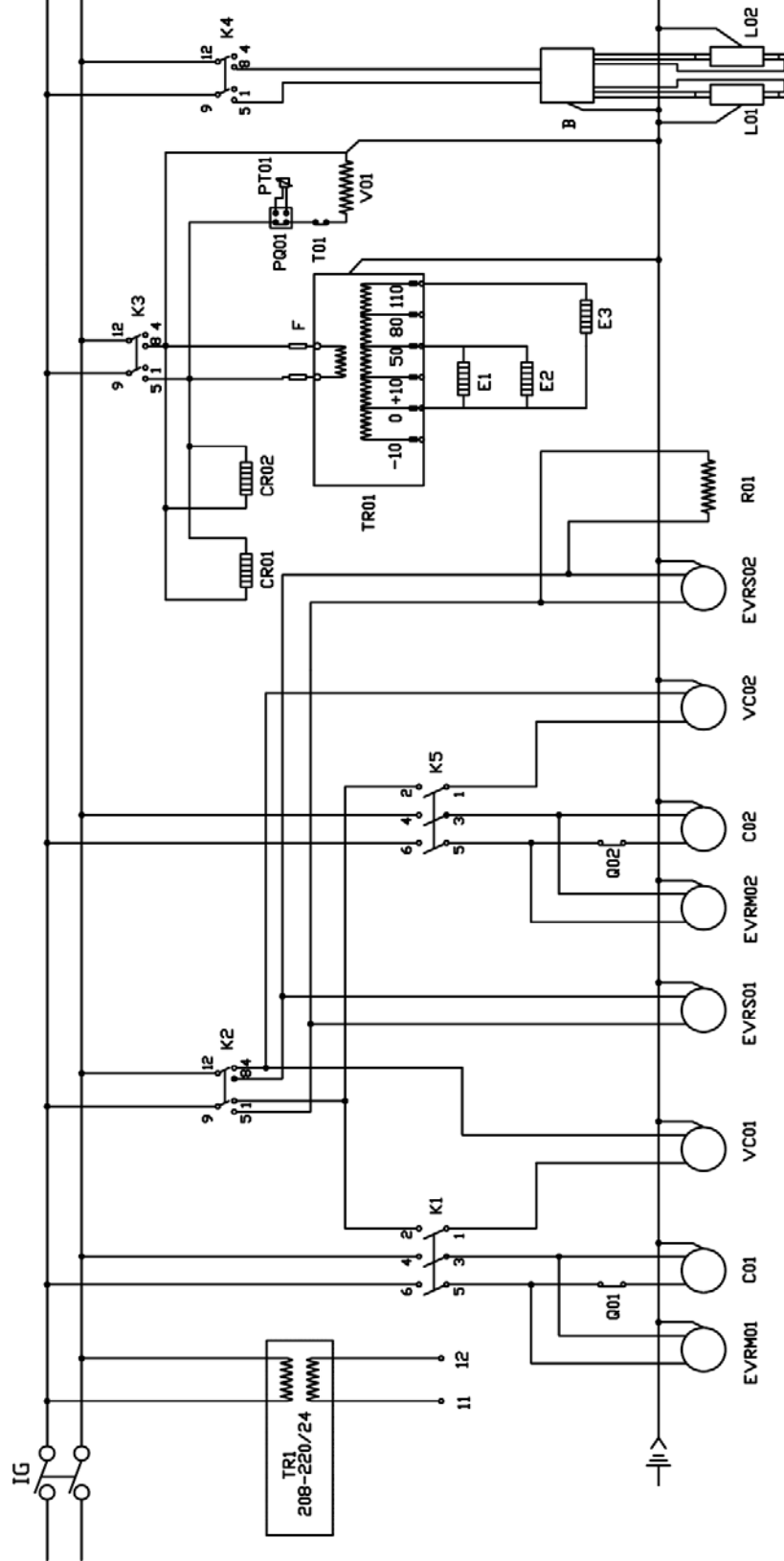

ELECTRICAL DIAGRAM VENTURA XP G6 - G9

SEMIHERMETIC

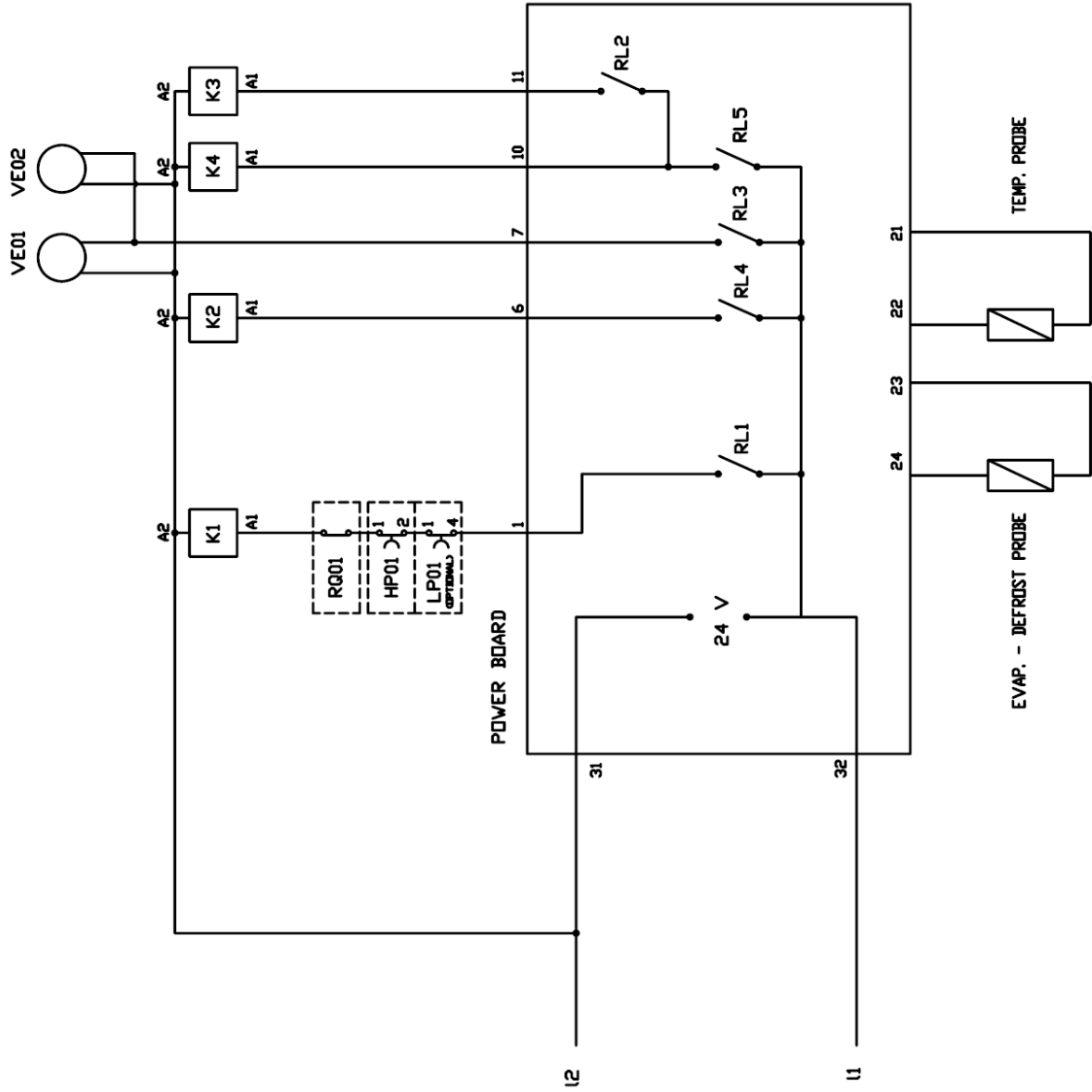

POWER WIRING VENTURA XP G6 - G9

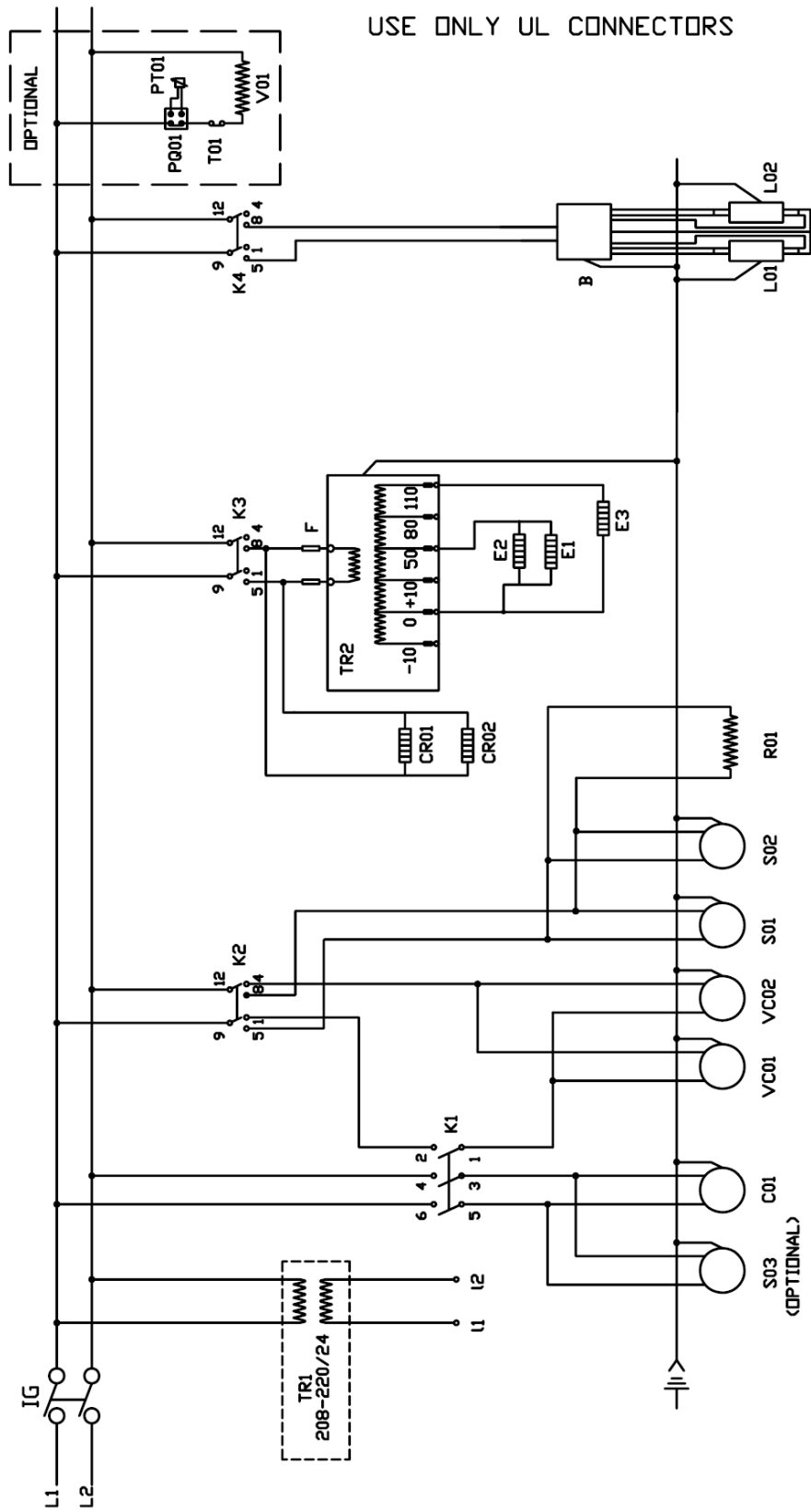

SEMIHERMETIC

ELECTRICAL DIAGRAM VENTURA XP G12

Electrical Diagram G12 24V

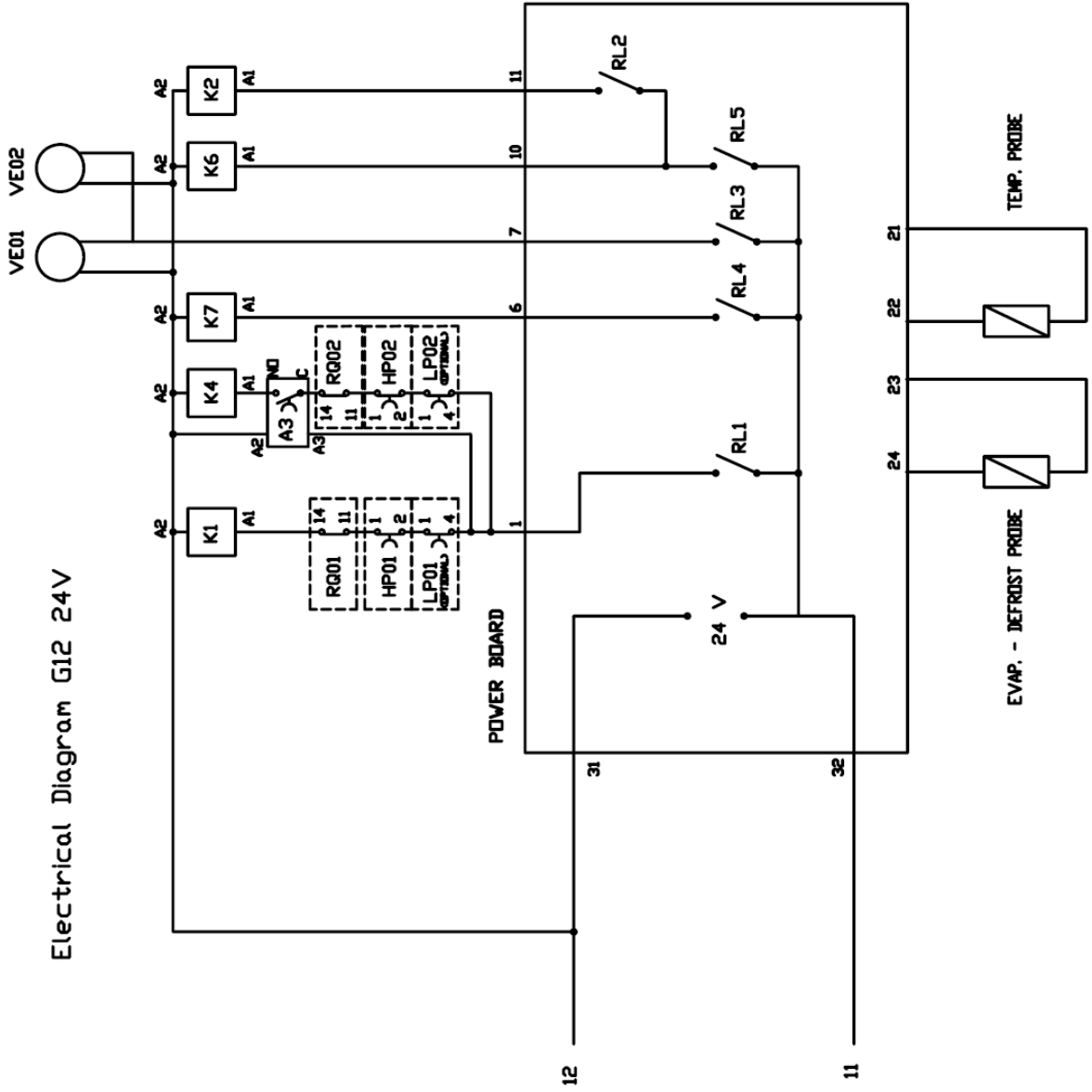

POWER WIRING VENTURA XP G12

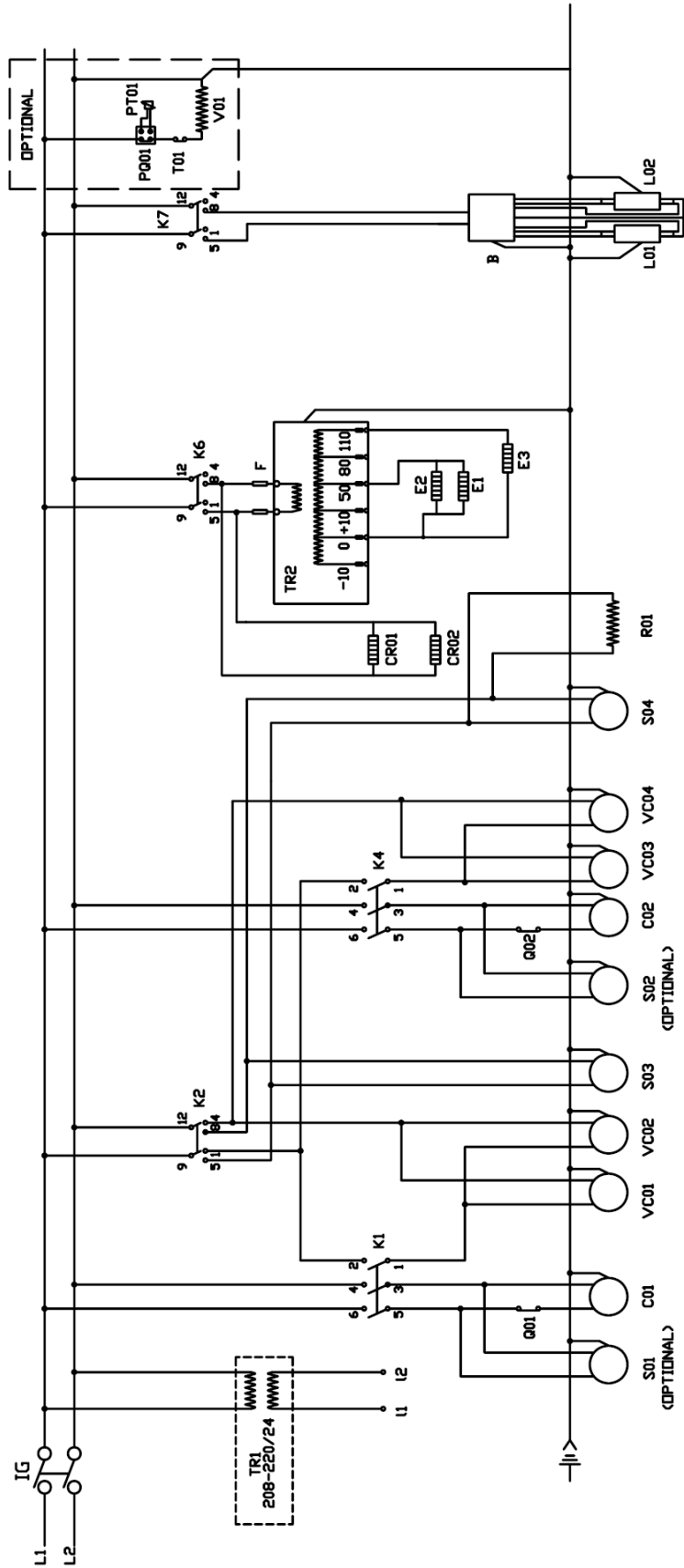

## 8. REFRIGERATOR PLANT DIAGRAM

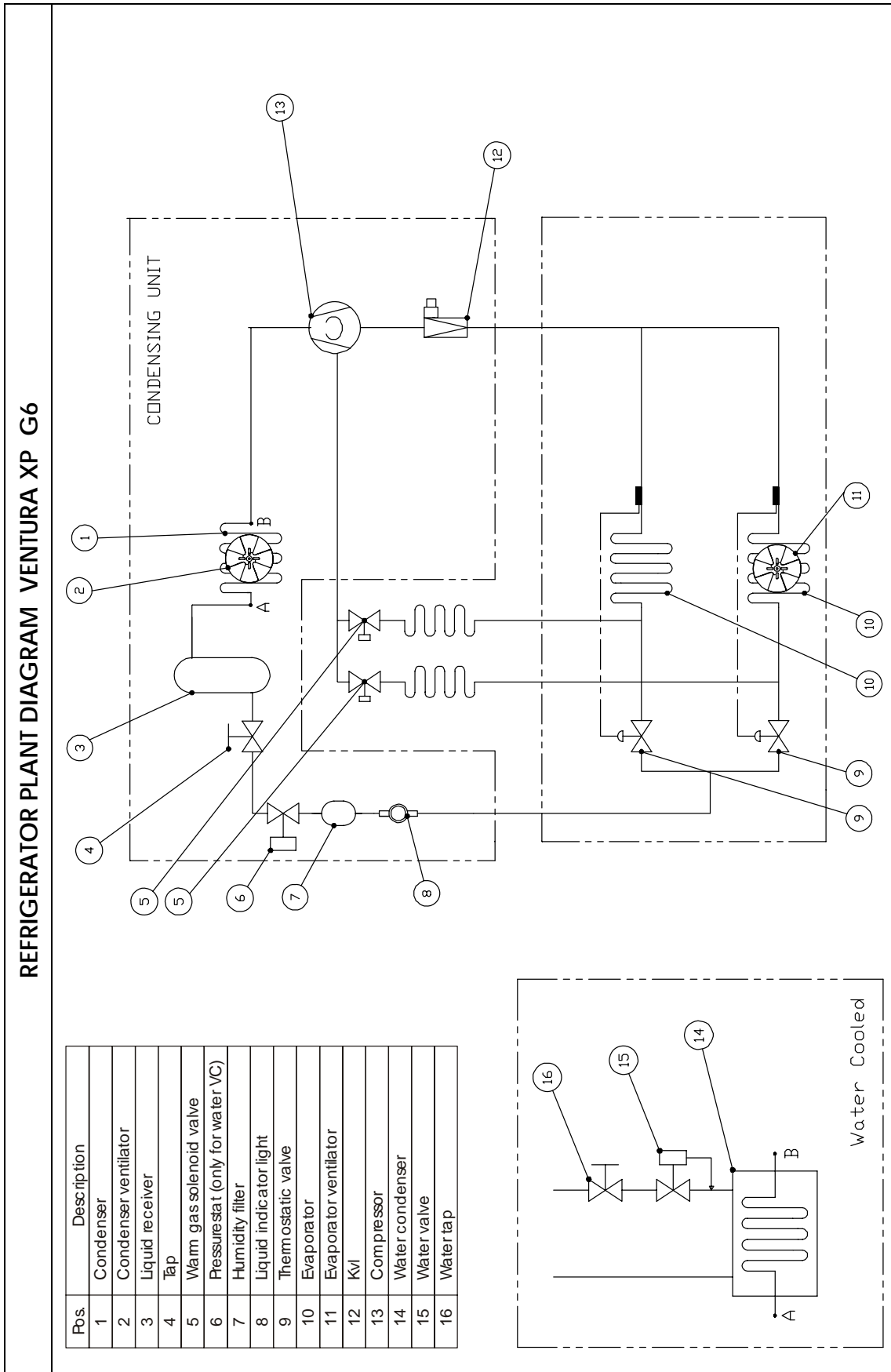



# REFRIGERATOR PLANT DIAGRAM VENTURA XP G9 - G12

Pbs.	Description
1	Condenser
2	Condenser ventilator
3	Liquid receiver
4	Tap
5	Warm gas solenoid valve
6	Pressurestat (only for water VC)
7	Humidity filter
8	Liquid indicator light
9	Thermostatic valve
10	Evaporator
11	Evaporator ventilator
12	K/I
13	Compressor
14	Water condenser
15	Water valve
16	Water tap

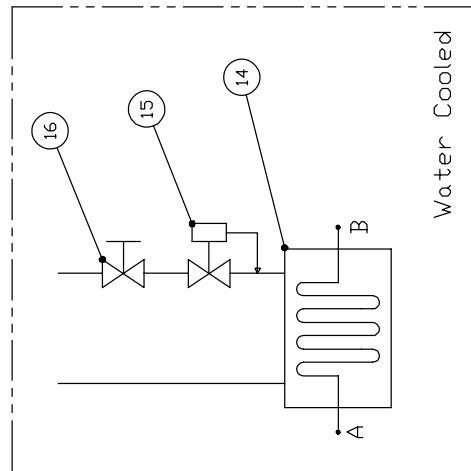
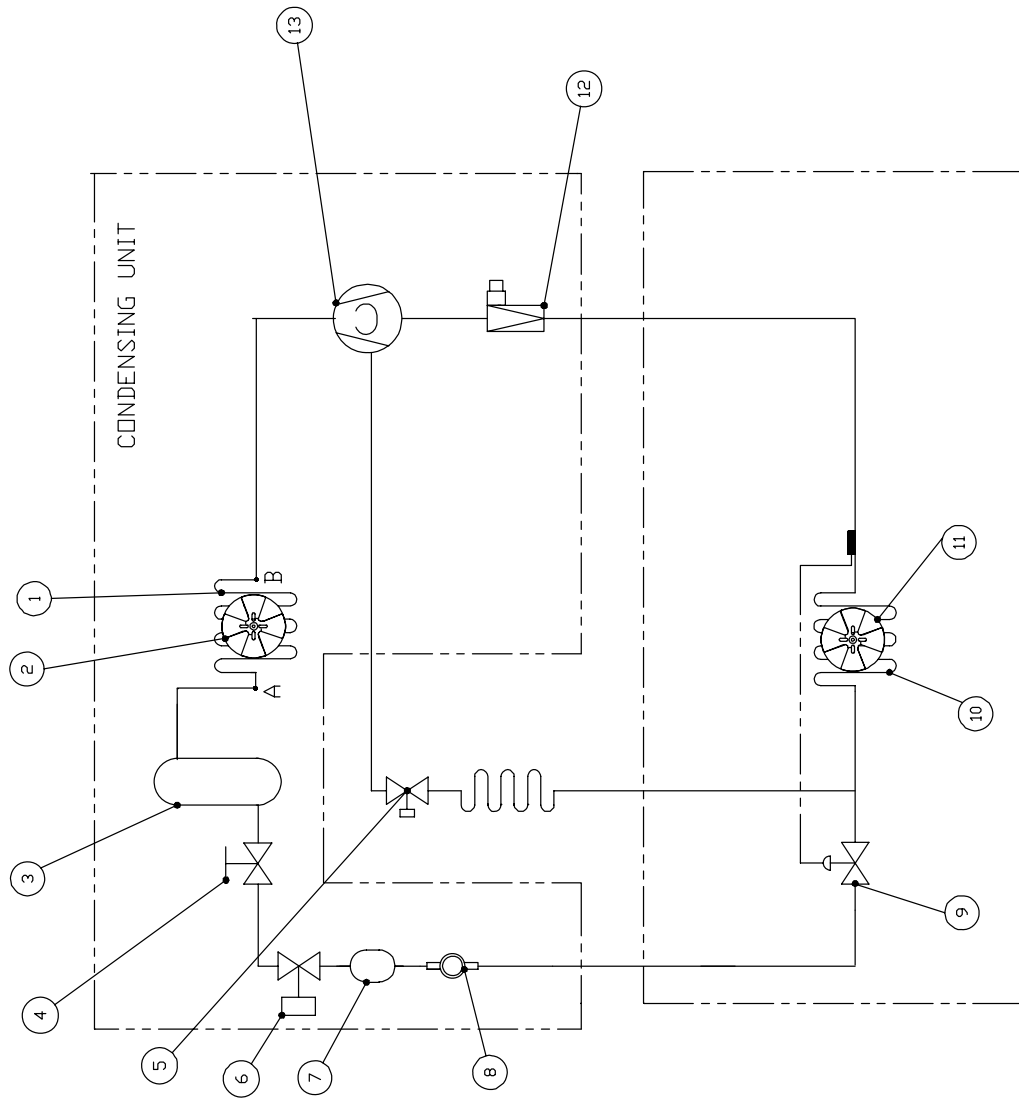



60035 JESI (An) Italy - ZIPA -Viale dell'Industria  
Tel. +39 0731 61531 - Fax +39 0731 6153413  
[www.clabogroup.com](http://www.clabogroup.com) - E-mail: [info@clabogroup.com](mailto:info@clabogroup.com)