

KT24

CHOCOLATE CURVED SHOWCASE

C87-KT24-C30EXT
C87-KT24-C30EXT-T

C87-KT24-C30INT

C87-KT24-C45EXT
C87-KT24-C45EXT-T

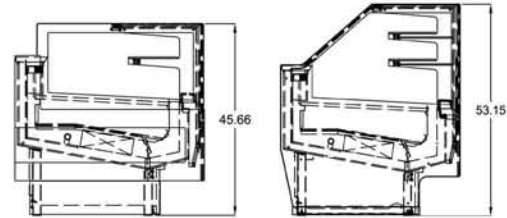

BID SPECIFICATIONS

STANDARD

- * ALL CLEAR PLEXIGLASS TOP SUPPORT STRUCTURE (FIG.1)
- * LED LIGHTING
- * TILT BACK FRONT GLASS
- * ALL TEMPERED, DOUBLE PANE GLASS FRONT AND SIDES
- * GALVANIZED STEEL CHASSIS CONSTRUCTION
- * INSULATED WITH DENSE NON-CFC ECOLOGIC POLYURETHANE FOAM
- * BACK & INSIDE STRUCTURE MADE OF HIGH GLOSS 304 STAINLESS STEEL
- * STAINLESS STEEL WORK SURFACE
- * DIGITAL DIAGNOSTIC CONTROL SYSTEM WITH PROGRAMMABLE DEFROSTING
- * REAR PLEXIGLASS SLIDING DOORS
- * AIR-COOLED CONDENSING UNIT

- * UNIQUE FAN ASSISTED AIRFLOW DESIGN
- * INCLINE DISPLAY
- * REMOVABLE STAINLESS STEEL DECK
- * SILVER ANODIZED ALUMINUM TRIM
- * STAINLESS STEEL WORK SURFACE
- * BACK PAINTED GLASS ON FRONT FACIA
- * REFRIGERATED DECK, NON-REFRIGERATED SHELVES
- * HUMIDITY CONTROL SYSTEM
- * MULTIPLEXING CAPABILITY WITH GELATO, PASTRY, DELI, AND CHOCOLATE CASE APPLICATIONS
- * DISPLAY CASE(S) TO BE SHIPPED FULLY ASSEMBLED
- * THE STANDARD LIMITED WARRANTY INCLUDES:
5 YEAR COMPRESSOR; 1 YEAR PARTS; 90 DAYS LABOR
- * DISPLAY CASE(S) TO BE LABORATORY CERTIFIED AS DESCRIBED



FIG.1

OPTIONAL

- * FULLY REFRIGERATED SHOWCASE OPTION
- * CASTERS
- * GRANITE WORK SURFACE (OPERATOR SIDE)
- * REMOTE CONDENSING UNIT

- * SIDE & FRONT PANELS PAINTED IN A GLOSSY FINISH (CASE SHIP IN BUFF WHITE PRIMER)



KT24 Chocolate Curved Refrigerated Case Technical Specifications

Updated Model no.	Factory Codes	Case Heights	* Case Lengths	Case Depth	Crated Weights (lb)	Line Voltage	Breaker Size	Amp Draw	Working Temp	Comp. HP	Shelves
C87-KT24-C30EXT	RP 30A	45.66"	*A & B*	45.12"	723	220/1/60	20amps	10	57	1/2 HP	1
C87-KT24-C30EXT-T	RP 30A	53.15"	*A & B*	45.12"	875	220/1/60	20amps	10	57	1/2 HP	2
C87-KT24-C30INT	RP 30C	45.66"	*A & B*	45.12"	934	220/1/60	20amps	10	57	1/2 HP	1
C87-KT24-C45EXT	RP 45A	45.66"	*A & B*	45.12"	875	220/1/60	20amps	10	57	1/2 HP	1
C87-KT24-C45EXT-T	RP 45A	53.15"	*A & B*	45.12"	934	220/1/60	20amps	10	57	1/2 HP	2

T = TALL

* Case lengths are specified with standard end panels

A - Customer Side
KT24-C30EXT = 62.23"

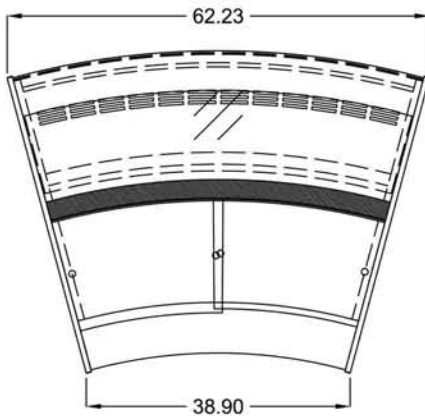

B - Server Side
KT24-C30EXT = 38.90"

A - Customer Side
KT24-C30INT = 37.40"

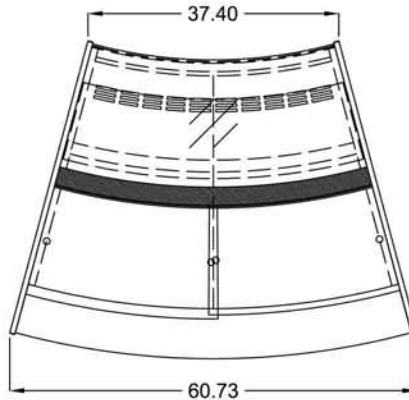

B - Server Side
KT24-C30INT = 60.73"

A - Customer Side
KT24-C45EXT = 57.56"

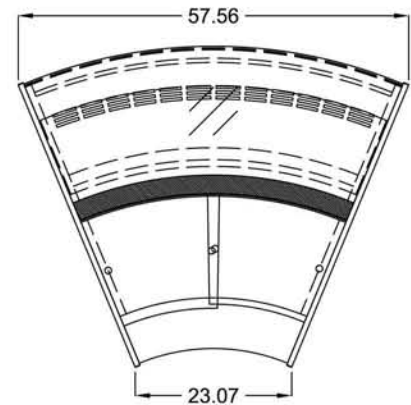

B - Server Side
KT24-C45EXT = 23.07"

PLAN / TOP VIEWS of CURVED CASES

LISTINGS:



ELECTRICAL CONNECTION

Display cases are shipped with applicable junction box for hardwired installation
Options exist for several NEMA configurations
Plug and/or receptacle configurations are at the discretion of the electrical installer

NOTE:

Required ambient conditions: 75°F; 55% RH
Drawing and Specifications are subject to change without notice

CLABO USA INC.
2556 Barrington Court,
Hayward, CA 94545 USA
PH 800.672.2784
FAX 510.441.0401
<http://www.otl-america.com>